

**NEW**

- Ensures positive alignment between mold halves
- All sizes in stock for immediate delivery
- Hardened & Precision Ground/Finished
- Extra stock for precision fitting
- 52100 Bearing Steel
- Female 60 - 63 R/C
- Male 60 - 63 R/C
- Laser Marked

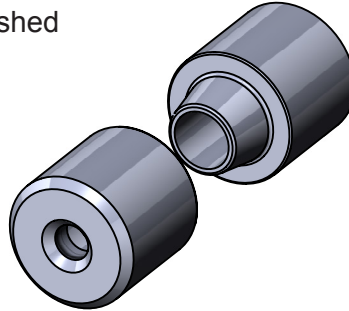

- **Special Design with Drill & Counterbore for Optional Front/Parting Line Installation!**
- **Ideal Substitution for Leader Pins & Bushings For Blow Mold Tooling**
- **Proudly Made in Michigan by Choice Mold Components**

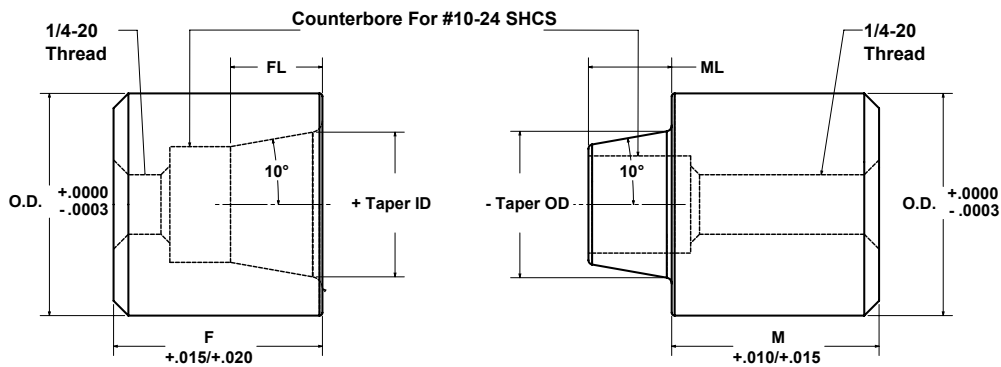

## FEMALE

OD	Taper ID	Tap Size	Taper Length	Female Length	Catalog Number	Price
			FL	F		
3/4	1/2	1/4-20 thread	1/4	11/16	RTF0611-10C	30.50
				7/8	RTF0614-10C	30.75
				1-3/16	RTF0619-10C	31.00
				1-3/8	RTF0622-10C	31.50
1	5/8	1/4-20 thread	9/32	11/16	RTF0811-10C	32.00
				7/8	RTF0814-10C	32.50
				1-3/16	RTF0819-10C	33.00
				1-3/8	RTF0822-10C	33.50

## MALE

OD	Taper OD	Tap Size	Taper Length	Male Length	Catalog Number	Price
			ML	M		
3/4	1/2	1/4-20 thread	1/4	11/16	RTM0611-10C	30.50
				7/8	RTM0614-10C	30.75
				1-3/16	RTM0619-10C	31.00
				1-3/8	RTM0622-10C	31.50
1	5/8	1/4-20 thread	9/32	11/16	RTM0811-10C	32.00
				7/8	RTM0814-10C	32.50
				1-3/16	RTM0819-10C	33.00
				1-3/8	RTM0822-10C	33.50

Prices subject to change without notice

**Also Available - Custom Taper Locks manufactured to your specifications**